

8 | 7 | 6 | 5 | 4 | 3 | 2 | 1

NOTES:-

- 1- BOLT ASSEMBLY- 12972691 MUST CAM FREELY IN KEY AND BOLT CARRIER ASSEMBLY- 8448505.
- 2- FIRING PIN- 8448503 MUST MOVE FREELY IN BOLT ASSEMBLY- 12972691.
- 3- FIRING PIN RETAINING PIN- 8448504 MUST BE SECURE AND MUST HOLD FIRING PIN SECURELY.
- 4- MIL-W-13855 APPLIES.

| REVISIONS |      |  |        |          |
|-----------|------|--|--------|----------|
| REF       | ZONE | DESCRIPTION  | DATE   | APPROVED |
| -         | -    | PRODUCT BASELINE<br>ERR G5S3081                                    | 951211 | HJS      |
| A         |      | NOR L7S3059 971016<br>(ECP L8S3000 980126)<br>(ECP L8S3007 980225) | 980213 | JB       |

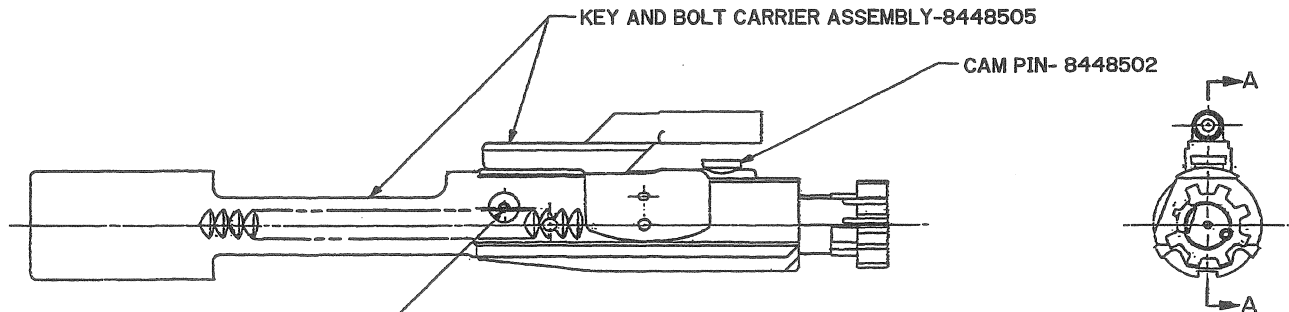

FIRING PIN RETAINING PIN- 8448504  
INSERT FROM OPPOSITE SIDE  
SEE NOTE 3

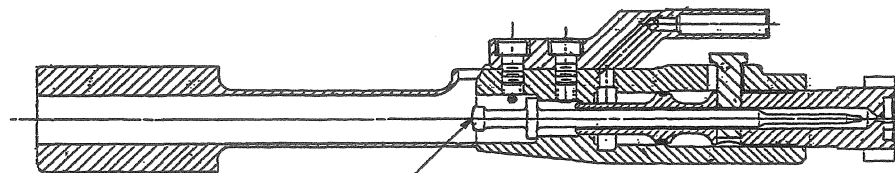

FIRING PIN- 8448503  
SEE NOTE 2

SECTION A-A

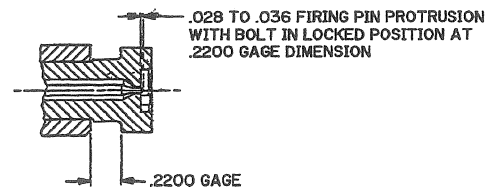

SEE PL- 8448501

PART NO. 12011849

DISTRIBUTION STATEMENT A.  
APPROVED FOR PUBLIC RELEASE;  
DISTRIBUTION IS UNLIMITED.

|                       |          |                   |   |                  |   |
|-----------------------|----------|-------------------|---|------------------|---|
| PMIC                  | 8448600  | M16               | DO NOT SCALE DRAWING<br>UNLESS OTHERWISE SPECIFIED<br>DIMENSIONS ARE IN INCHES<br>TOLERANCES ON<br>DECIMAL FRACTION<br>2 PL ±<br>3 PL ± | CONTRACT NUMBER  | DESIGN ACTIVITY<br>U.S. ARMY<br>ARMAMENT RESEARCH DEVELOPMENT AND ENGINEERING CENTER<br>PITMAN ARSENAL, NEW JERSEY 07095-9000 |
|                       | 8448500  | M16A1             |   |                  |   |
| MECHANICAL PROPERTIES | 9349000  | M16A2             | THIRD ANGLE PROJECTION  | CONTRACTOR       | DRAWN BY HJS DATE 951211  |
|                       | 12973001 | M16A4             |   |                  |   |
| YP                    | 12012000 | M16A3             | DRAWING APPROVAL  | CHECKER ENGINEER | SCALE D 19200   |
| ITS                   | 12972700 | M4A1              |   |                  |   |
| SL2                   | 9390000  | M4                | DESIGN APPROVAL   | SCALE 2/1        | CAGE CODE 12011849  |
| RA                    |          |                   |   |                  |   |
| BH                    |          | NEXT ASSY USED ON |   |                  |   |
| RH                    |          | APPLICATION       |   |                  | SHEET   |