

5

4

3

2

1

NOTICE: RESTRICTED AS TO USE AND DISCLOSURE

THIS ENTIRE DOCUMENT AND ALL INFORMATION THEREON IS PROPRIETARY TO COLT'S INC AND SHALL NOT BE REPRODUCED, DUPLICATED OR COPIED IN WHOLE OR IN PART, DISCLOSED OR MADE AVAILABLE TO ANY OTHER PERSON, FIRM, OR CORPORATION OR OTHERWISE USED EXCEPT TO THE EXTENT NECESSARY FOR AND THEN ONLY IN CONNECTION WITH THE PREPARATION AND/OR SUBMISSION OF BIDS OR PROPOSALS RELATED TO A PROCUREMENT BEING EFFECTED BY THE UNITED STATES GOVERNMENT OR IN CONNECTION WITH THE MANUFACTURE IN THE UNITED STATES ORDER BY THE UNITED STATES GOVERNMENT OR UNDER A CONTRACT WITH THE UNITED STATES GOVERNMENT. THIS DOCUMENT WILL BE DISPOSED OF IN ACCORDANCE WITH INSTRUCTIONS ISSUED BY THE RESPONSIBLE CONTRACTING OFFICER UPON COMPLETION OF THE PURPOSE FOR WHICH IT WAS ISSUED.

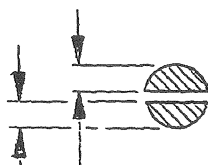

EQUAL WITHIN .005 (TRUE)

SECTION C-C

NOTES

1. FINISH 125 $\sqrt{}$
2. HEAT TREATMENT: QUENCH AND TEMPER TO HARDNESS (B) SPECIFIED.
3. FINISH 5.3.1.2 OF MIL-STD-171.
4. MIL-W-13855 APPLIES.

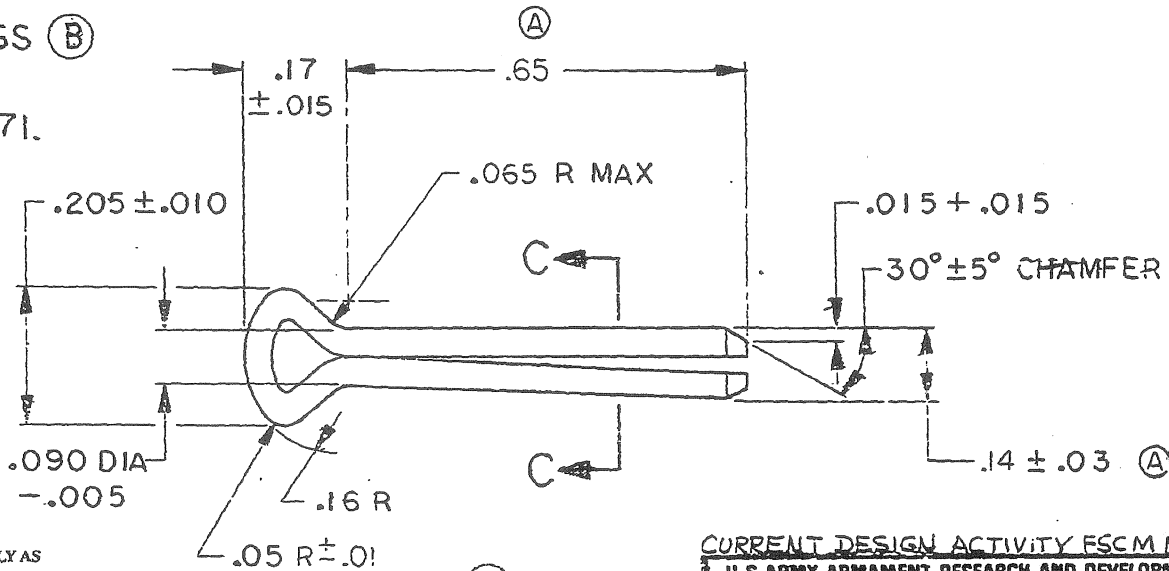

REVISIONS					
MF	ZONE	LTR	DESCRIPTION	DATE	APPROVED
			REDRAWN FROM COLT'S DRAWING	27 APR 70	
			C62335 REVISION B		
		A	(2) SEE EO HRD 02197-3	15 JUL 70	JPS
		B	(4) SEE ERR HQR 20778	5 OCT 72	RC
		C	NOR W9S2009 80-02-13	80-05-16	
		D	NOR W2S3258 / 82-12-30	84-09-04	
		E	NOR GIS2018 91-07-08	91-10-11	
		F	NOR G3S2019 / 930701	330301	CHS

B8448504

"DISTRIBUTION STATEMENT E. FURTHER DISSEMINATION ONLY AS DIRECTED BY ASQC-AR, 91025, OR HIGHER DoD AUTHORITY."

CURRENT DESIGN ACTIVITY FSCM NO. 19200
U S ARMY ARMAMENT RESEARCH AND DEVELOPMENT CENTER
DOVER, NEW JERSEY 07801

MECHANICAL PROPERTIES		UNLESS OTHERWISE SPECIFIED DIMENSIONS ARE IN INCHES		CONTRACT NO		DEPT OF THE ARMY	
YS MIN		TOLERANCES:		DATE 27 APR 1970		US ARMY WEAPONS COMMAND	
YS MAX	8448501	ANGLES ±		PREP	C.B.H. A.S.M.	ROCK ISLAND, ILLINOIS, 62401	
EL 2	D9327072	3 PLACE DECIMALS ± .005		CHK	M.T.H. W. Anderson	PIN, RETAINING, FIRING PIN	
RA		2 PLACE DECIMALS ± .01		ENGR	D. Hunt O. Billiet	SIZE CODE IDENT NO DRAWING NO.	
BH	D8448501	MATERIAL		SUBMITTED		B 19204	8448504
RH	15N-305-835	WIRE, STEEL, CMPSN		APPROVED	R. L. Henry	SCALE 5/1	SHEET 1 OF 1
		1038, ASTM A510					
		FINAL PROTECTIVE FINISH					
		SEE NOTE 3					
		APPLICATION					

(B)

A