

NOTICE: RESTRICTED AS TO USE AND DISCLOSURE

THIS ENTIRE DOCUMENT AND ALL INFORMATION THEREIN IS PROPRIETARY TO COLT'S INC AND SHALL NOT BE REPRODUCED, SIMULATED OR COPIED IN WHOLE OR IN PART, DISCLOSED, OR MADE AVAILABLE TO ANY OTHER PERSON, FIRM, OR CORPORATION OR OTHERWISE USED EXCEPT TO THE EXTENT NECESSARY FOR AND THEN ONLY IN CONNECTION WITH THE PROPRIETARY DEVELOPMENT, MANUFACTURE, USE OR PROPOSALS RELATED TO A PROGRAMME BEING EFFECTED BY THE UNITED STATES GOVERNMENT OR IN CONNECTION WITH THE MANUFACTURE IN THE UNITED STATES OTHER BY THE UNITED STATES GOVERNMENT OR HEREIN IN CONNECTION WITH THE UNITED STATES GOVERNMENT. THIS DOCUMENT SHALL BE DISPOSED OF IN ACCORDANCE WITH INSTRUCTIONS ISSUED BY THE PROGRESSIVE CONTRACTING OFFICER UPON COMPLETION OF THE PURPOSE FOR WHICH IT WAS ISSUED.

NOTES:

1. AL ALLOY, 7075-T6 OR T651, COLD DRAWN PER QQ-A-225/9 OR AL ALLOY, 7075-T6 OR T6510 EXTRUDED PER QQ-A-200/11.
2. FINISH 125.
3. FILLET RADIUS TO BE .03.
4. BREAK SHARP EDGES .010 MAX.
5. ALL DIAMETERS TO BE [B].010 DIA EXCEPT AS NOTED. (A) (E)
6. ALL DIMENSIONS APPLY BEFORE FINISH.
7. FINISH MIL-A-8625, TYPE III, CLASS I, SEALED, [B] FILM THICKNESS .0010 \pm .0002.
8. MIL-W-13855 APPLIES.

REVISIONS					
NO	ZONE	LTR	DESCRIPTION	DATE	APPROVED
			REDRAWN FROM COLT'S DRAWING D'62340 REV. 8	27 APR 70	
A	(1)		SEE EO HQR 0297-3	15 JULY 70	
B	(H)		SEE EO HQR 02257	15 OCT 70	
C	(G)		SEE EO HQR 10649	20 FEB 71	
D	(3)		SEE ERR HQR 10836	13 SEP 71	
E	(4)		SEE ERR HQR 20778	6 OCT 72	
F			NOR WAS 3048 / 84-10-09 (ECP WAS 0041 / 84-12-18)	05-02-14	

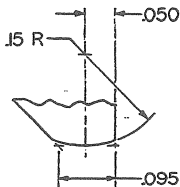

VIEW B
SCALE 10/1 (C)

3 FLATS EQUALLY SPACED WITHIN $\pm 10^\circ$ (C)

(E) .068 DIA $\pm .020$, .030 DEEP CENTER PERMISSIBLE

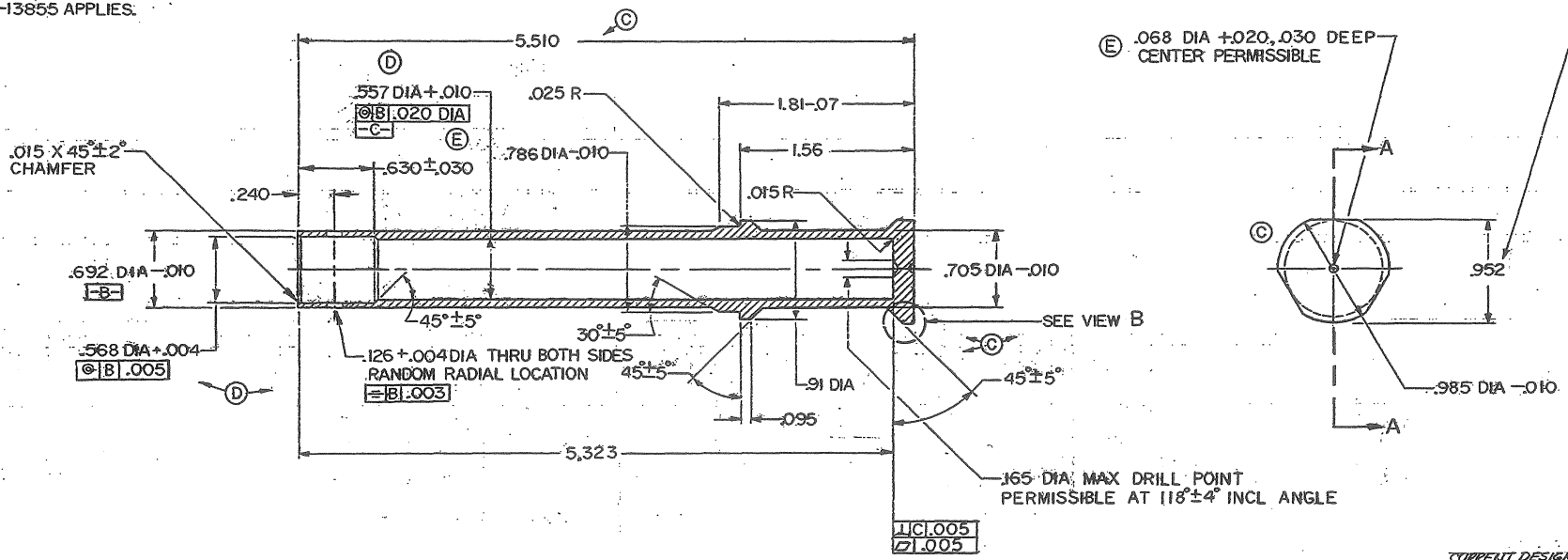

SECTION A-A

CURRENT DESIGN ACTIVITY ESCM NUMBER
U.S. ARMY ARMAMENT RESEARCH AND DEVELOPMENT CENTER
DOWEL, NEW JERSEY 07001

MECHANICAL PROPERTIES		UNLESS OTHERWISE SPECIFIED TOLERANCES ARE IN INCHES		CONTRACT NO.	
YS MIN		TOLERANCES:		DATE 27 APR 1970	
YS MAX		ANGLES - C		PREPARED BY [Signature]	
EL 2		3 PLACE DECIMALS $\pm .005$		CHECKED BY [Signature]	
RA		2 PLACE DECIMALS $\pm .01$		ENGINEER [Signature]	
BN		MATERIAL		SUBMITTED BY [Signature]	
BN		SEE NOTE 1		APPROVED [Signature]	
BN		MILG		DATE 27 APR 1970	
BN		GRAABIS MILGAM		PREPARED BY [Signature]	
BN		NEXT ASSY USED ON APPLICATION		CHECKED BY [Signature]	
BN		MIL PROTECTIVE FINISH		ENGINEER [Signature]	
BN		SEE NOTE 7		SUBMITTED BY [Signature]	
				DEPT OF THE ARMY U.S. ARMY WEAPONS COMMAND ROCK ISLAND, ILLINOIS 61201	
				BODY, BUFFER	
				SIZE CODE BODY NO. DRAWING NO.	
				D 19204 8448616	
				SCALE 2/1	
				SHEET 1 OF 1	

October 15, 2004 11:11 AM

D 8448616

A

CDI