

4 3 2 1

NOTICE: RESTRICTED AS TO USE AND DISCLOSURE

THIS ENTIRE DOCUMENT AND ALL INFORMATION THEREON IS PROPRIETARY TO COLTS INC AND SHALL NOT BE REPRODUCED, DUPLICATED OR COPIED IN WHOLE OR IN PART, DISCLOSED OR MADE AVAILABLE TO ANY OTHER PERSON, FIRM, OR CORPORATION OR OTHERWISE USED EXCEPT TO THE EXTENT NECESSARY FOR AND THEN ONLY IN CONNECTION WITH THE PREPARATION AND/OR SUBMISSION OF BIDS OR PROPOSALS, RELATED TO A PROCUREMENT BEING EFFECTED BY THE UNITED STATES GOVERNMENT OR IN CONNECTION WITH THE MANUFACTURE IN THE UNITED STATES BY THE UNITED STATES GOVERNMENT OR UNDER A CONTRACT WITH THE UNITED STATES GOVERNMENT. THIS DOCUMENT WILL BE DISPOSED OF IN ACCORDANCE WITH INSTRUCTIONS ISSUED BY THE RESPONSIBLE CONTRACTING OFFICER UPON COMPLETION OF THE PURPOSE FOR WHICH IT WAS ISSUED.

REVISIONS					
MF	ZONE	LTR	DESCRIPTION	DATE	APPROVED
M		A	(2) SEE EO HRD-02231	25 AUG 70	<i>[Signature]</i>
		B	(4) SEE ERR HQR 20778	6 OCT 72	R.C.
		C	SEE ERR HQF 30671	22 MAR 73	X B
		D	NOR W250029 82-07-15	83-02-03	<i>[Signature]</i>
		E	NOR W25 0026 82-05-21	83-09-22	<i>[Signature]</i>
		F	NOR W5S8004 / 860204	890215	<i>[Signature]</i>
		G	NOR G6S3149 961024	961215	JB

NOTES:

1. BLANK EDGES 250/
2. FINISH 125/ EXCEPT AS NOTED.
3. FINISH 5.3.1.2 OR 5.3.2.2 OF MIL-STD-171.
4. BREAK SHARP EDGES .005 +.010.
5. MIL-W-13855 APPLIES.

DIRECTION OF GRAIN

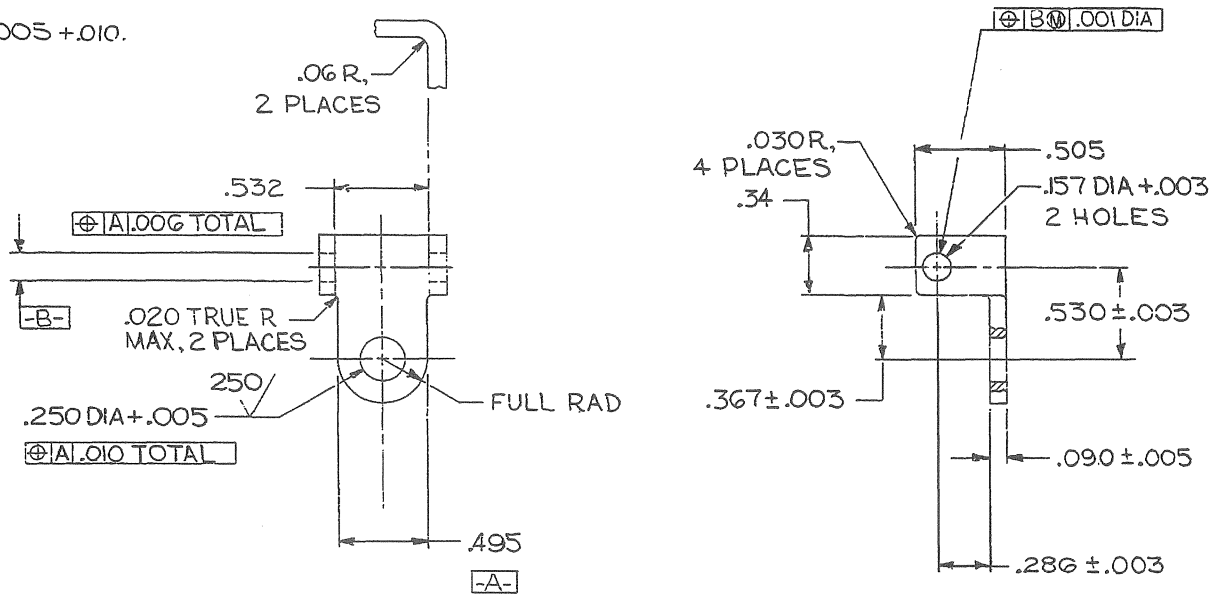

CURRENT DESIGN ACTIVITY CAGE CODE 19200
U.S. ARMY
ARMAMENT RESEARCH, DEVELOPMENT AND ENGINEERING CENTER
PICATINNY ARSENAL, NEW JERSEY 07806-5000

MECHANICAL PROPERTIES		UNLESS OTHERWISE SPECIFIED DIMENSIONS ARE IN INCHES		CONTRACT NO: <i>[M]</i>		DEPT OF THE ARMY U.S. ARMY WEAPONS COMMAND ROCK ISLAND, ILLINOIS, 61201	
YS MIN		TOLERANCES: ANGLES ± 3 PLACE DECIMALS ± .005 2 PLACE DECIMALS ± .01		DATE 5 JUN 70		HINGE	
YS MAX		MATERIAL		PREPARED <i>T. A. Wilson R. Passig</i>			
EL 2		STEEL, CMPSN 1010, THER 1020 SPEC ASTM A109		CHECKED <i>[Signature]</i>		SIZE CODE IDENT NO DRAWING NO. C 19204 8448653	
RA		MIG, MIG A2		ENGINEER <i>[Signature]</i>			
BH		D9349119 MIG A1		SUBMITTED		SCALE 2/1 SHEET OF	
RH		NEXT ASSY USED ON		APPROVED <i>[Signature]</i>			
APPLICATION		FINAL PROTECTIVE FINISH		SEE NOTE 3			

C 8448653