

8 7 6 5 4 3

REV	DESCRIPTION	DATE	APPROVAL
-	PRODUCTION RELEASE ERWES-2013	820614	
A	NORW353114/83-05-05	830810	
B	NORW450030/84-11-15	850402	
C	NORW53004/85-03-08 ECP W53003/85-03-28	850625	
D	NORW650001 86-01-17	860304	
E	NORW653062/86204	870915	
F	NOR W558004 960204	890215	
G	ERR 751/282 AK G (ECP) 5316/8801221 ECP (952031/890706) ECP (953090/900405)	901115	
H	NOR G053115/900718	910130	
J	NOR G153099 910814	911101	
K	NOR G153143 911013	920122	
L	NOR L759451/970806	971002	FET

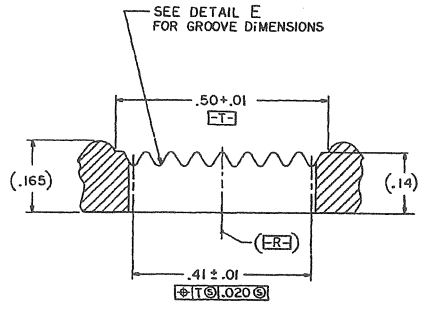

DETAIL F
ROTATED 90° CCW
SCALE: 10/1

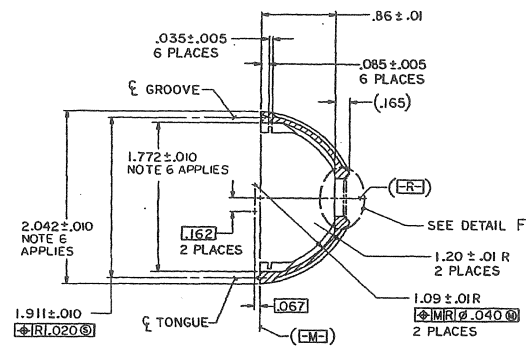

SECTION C-C
NOTE 6

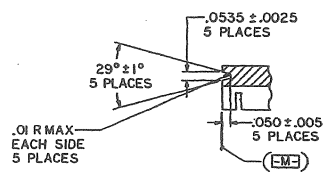

SECTION G-G
SCALE: 4/1

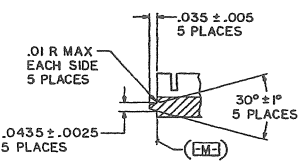

SECTION H-H
SCALE: 4/1

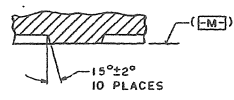

SECTION K-K
SCALE: 4/1

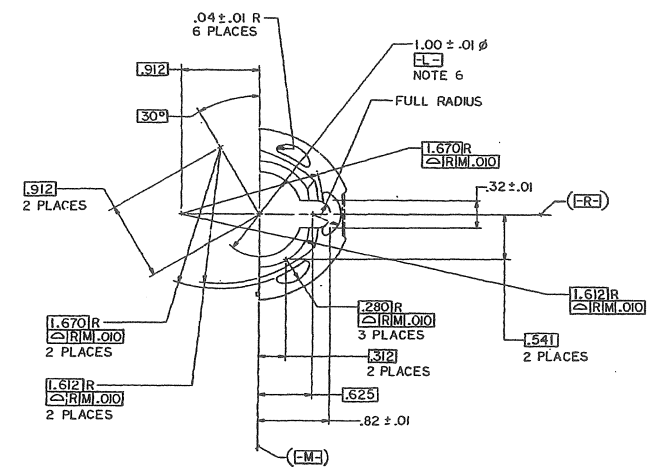

VIEW N-N

A

OR
5

-.125 R
04 ± .01 R
ALL AROUND
3 PLACES

1.125 R

140 ± .005
75 ± .005
PLACES

162 ± .010 R

(-M)

125 ± .010 R
3 PLACES

October 14, 2004 12:29 AM

DWG NO.	SH	REV	FRAME
9349060	1	L 3	OF 3

MECHANICAL PROPERTIES		DO NOT SCALE DRAWING	ORIGINAL DATE OF DRAWING	11.5 ARMY ARMAMENT RESEARCH AND DEVELOPMENT CENTER
YF	YB	UNLESS OTHERWISE SPECIFIED	92-02-26	DOVER NEW JERSEY 08003
YD	YK	TOLERANCES ON DIMENSIONS*	UNLESS OTHERWISE SPECIFIED	
YH	YJ	FRACTIONS ±	DECIMALS ±	
YI	YL	ANGLES ±	ANGLES ±	
YM	YN	APPROVALS		
YO	YP			
YQ	YR			
YS	YT			
YU	YV			
YW	YX			
YY	YZ			
YAA	YAB			
YAC	YAD			
YAE	YAF			
YAG	YAH			
YAI	YAJ			
YAK	YAL			
YAM	YAN			
YAO	YAP			
YAQ	YAR			
YAS	YAT			
YAU	YAV			
YAW	YAX			
YAY	YAZ			
YBA	YBB			
YBC	YBD			
YBE	YBF			
YBG	YBH			
YBI	YBJ			
YBK	YBL			
YBM	YBN			
YBO	YBP			
YBQ	YBR			
YBS	YBT			
YBU	YBV			
YBW	YBX			
YBY	YBZ			
YCA	YCB			
YCC	YCD			
YCE	YCF			
YCG	YCH			
YCI	YCJ			
YCK	YCL			
YCM	YCN			
YCO	YCP			
YCQ	YCR			
YCS	YCT			
YCU	YCV			
YCW	YCX			
YCY	YCZ			
YDA	YDB			
YDC	YDD			
YDE	YDF			
YDG	YDH			
YDI	YDJ			
YDK	YDL			
YDM	YDN			
YDO	YDP			
YDQ	YDR			
YDS	YDT			
YDU	YDV			
YDW	YDX			
YDY	YDZ			
YEA	YEB			
YEC	YED			
YEE	YEF			
YEG	YEH			
YEI	YEJ			
YEK	YEL			
YEM	YEN			
YEO	YEP			
YEQ	YER			
YES	YET			
YEU	YEV			
YEW	YEX			
YEY	YEZ			
YFA	YFB			
YFC	YFD			
YFE	YFF			
YFG	YFH			
YFI	YFJ			
YFK	YFL			
YFM	YFN			
YFO	YFP			
YFQ	YFR			
YFS	YFT			
YFU	YFV			
YFW	YFX			
YFY	YFZ			
YGA	YGB			
YGC	YGD			
YGE	YGF			
YGG	YGH			
YGI	YGJ			
YGK	YGL			
YGM	YGN			
YGO	YGP			
YGQ	YGR			
YGS	YGT			
YGU	YGV			
YGW	YGX			
YGY	YGZ			
YHA	YHB			
YHC	YHD			
YHE	YHF			
YHG	YHH			
YHI	YHJ			
YHK	YHL			
YHM	YHN			
YHO	YHP			
YHQ	YHR			
YHS	YHT			
YHU	YHV			
YHW	YHX			
YHY	YHZ			
YIA	YIB			
YIC	YID			
YIE	YIF			
YIG	YIH			
YII	YIJ			
YIK	YIL			
YIM	YIN			
YIO	YIP			
YIQ	YIR			
YIS	YIT			
YIU	YIV			
YIW	YIX			
YIY	YIZ			
YJA	YJB			
YJC	YJD			
YJE	YJF			
YJG	YJH			
YJI	YJJ			
YJK	YJL			
YJM	YJN			
YJO	YJP			
YJQ	YJR			
YJS	YJT			
YJU	YJV			
YJW	YJX			
YJY	YJZ			
YKA	YKB			
YKC	YKD			
YKE	YKF			
YKG	YKH			
YKI	YKJ			
YKK	YKL			
YKM	YKN			
YKO	YKP			
YKQ	YKR			
YKS	YKT			
YKU	YKV			
YKW	YKX			
YKY	YKZ			
YLA	YLB			
YLC	YLD			
YLE	YLF			
YLG	YLH			
YLI	YLJ			
YLK	YLL			
YLM	YLN			
YLO	YLP			
YLQ	YLR			
YLS	YLT			
YLU	YLV			
YLW	YLX			
LYY	YLZ			
YMA	YMB			
YMC	YMD			
YME	YMF			
YMG	YMH			
YMI	YMJ			
YMK	YML			
YMM	YMN			
YMO	YMP			
YMQ	YMR			
YMS	YMT			
YMU	YMV			
YMW	YMX			
MYY	MYZ			
YNA	YNB			
YNC	YND			
YNE	YNF			
YNG	YNH			
YNI	YNJ			
YNK	YNL			
YNM	YNN			
YNO	YNP			
YNQ	YNR			
YNS	YNT			
YNU	YNV			
YNW	YNX			
YNY	YNZ			
YOA	YOB			
YOC	YOD			
YOE	YOF			
YOG	YOH			
YOI	YOJ			
YOK	YOL			
YOM	YON			
YOO	YOP			
YOO	YOR			
YOS	YOT			
YOU	YOV			
YOW	YOX			
YOY	YOZ			
YPA	YPB			
YPC	YPD			
YPE	YPF			
YPG	YPH			
YPI	YPJ			
YPK	YPL			
YPM	YPN			
YPO	YPP			
YPO	YPR			
YPS	YPT			
YPU	YPV			
YPW	YPX			
OPY	OPY			

PART NO. 9349060

HANDGUARD

ESC/M/J
19200
9349060

SCALE: 2/1 SHEET 1 OF 1

3 - FD

8

7

6

5

4

3

1

2

1

3 - FD