

DRAWING SIZE D
(ARRADCOMR 70-12)

NOTICE: RESTRICTED AS TO USE AND DISCLOSURE
 THIS OTHER DOCUMENT AND ALL INFORMATION THEREON IS PROPRIETARY TO CRDC INC AND SHALL NOT BE REPRODUCED, DUPLICATED OR COPIED IN WHOLE OR IN PART, NEITHER ON IMAGE AVAILABLE TO ANY OTHER PERSON, FIRM OR CORPORATION OR OTHERWISE UNDER ANY LAW TO THE EXTENT NECESSARY FOR AND THEN ONLY IN CONNECTION WITH THE PERFORMANCE AND/OR SUBSEQUENCE OF WORK OR PROPRIETARY RELATED TO A PROCUREMENT BEING EFFECTED BY THE UNITED STATES GOVERNMENT OR IN CONNECTION WITH THE MANUFACTURE IN THE UNITED STATES PERFORMED BY THE UNITED STATES GOVERNMENT OR UNDER A CONTRACT WITH THE UNITED STATES GOVERNMENT. THIS DOCUMENT WILL BE DISPOSED OF IN ACCORDANCE WITH INSTRUCTIONS ISSUED BY THE RESPONSIBLE CONTRACTING OFFICER UPON COMPLETION OF THE PURPOSE FOR WHICH IT WAS ISSUED.

REVISIONS			
SYM	DESCRIPTION	DATE	APPROVAL
—	PRODUCTION RELEASE ERRW252013	820614	<i>[Signature]</i>
A	NOR W45 0030/ 84-11-15	850402	<i>[Signature]</i>

NOTES:—
 1— SPEC. MIL-W-13855 AND ANSI Y14.5-73 APPLY.

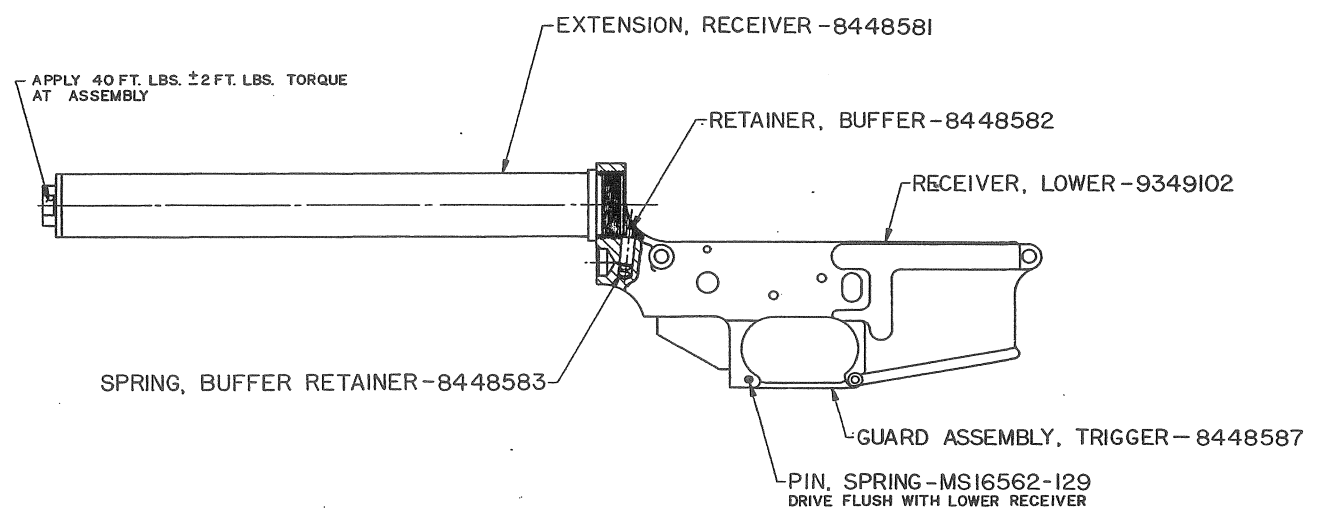

FOR ENGINEERING PARTS LIST SEE PL934910I

PART NO. 934910I
 U S ARMY ARMAMENT RESEARCH AND DEVELOPMENT CENTER
 DAVEN, NEW JERSEY 07801

MECHANICAL PROPERTIES		DO NOT SCALE DRAWING		ORIGINAL DATE OF DRAWING 82-02-25	
TP		UNLESS OTHERWISE SPECIFIED		DRAFTSMAN MM CHECKER JWH	
TS		DIMENSIONS ARE IN INCHES		ENGR <i>[Signature]</i> ENGR	
ELZ		TOLERANCES ON DECIMALS =		ENGR <i>[Signature]</i> ENGR	
RA		FRACTIONS = ANGLES =		SIZE D FSCM NO 19200 934910I	
BN				SCALE 1/1 UNIT WT. SHEET 1 OF 1	
9349100	M16A1E1				
NEXT ASSY	USED ON				
APPLICATION					

October 18, 2004 7:09 AM

ARRADCOMR FORM 60 AUG 77 REPLACES DAHQA FORM 1048 NOV 73 WHICH MAY BE USED UNTIL EXHAUSTED