

THIS DRAWING AND ALL INFORMATION THEREON IS PROPRIETARY TO THE U.S. GOVERNMENT. REPRODUCTION OR DISSEMINATION OF THIS INFORMATION IS PROHIBITED WITHOUT THE EXPRESS WRITTEN PERMISSION OF THE U.S. GOVERNMENT. THIS DRAWING IS THE PROPERTY OF THE U.S. GOVERNMENT AND IS LOANED TO YOU BY THE U.S. GOVERNMENT. IT IS TO BE USED ONLY FOR THE PURPOSES AUTHORIZED BY THE U.S. GOVERNMENT. IT IS TO BE RETURNED TO THE U.S. GOVERNMENT AT THE END OF THE LOAN PERIOD. IT IS TO BE KEPT IN A SAFE PLACE AND NOT TO BE REPRODUCED OR DISSEMINATED IN ANY MANNER WITHOUT THE EXPRESS WRITTEN PERMISSION OF THE U.S. GOVERNMENT. THE U.S. GOVERNMENT ASSUMES NO LIABILITY FOR THE USE OR MISUSE OF THIS INFORMATION.

- NOTES:-
- 1 - SPEC MIL-W-13855 AND ANSI Y14.5-73 APPLY.
 - 2 - MATERIAL:- PLASTIC COMPOUND PER ASTM D4066, PA 62. COLOR SHALL BE LUSTERLESS FLAT, APPROX. BLACK NO. 37038, TABLE IX, BUT NOT LIGHTER THAN GRAY, NO. 36076 TABLE VIII OF FED-STD-595.
 - 3 - BREAK SHARP EDGES .010±.005 UNLESS OTHERWISE NOTED.
 - 4 - FILLET RADII .009±.006 UNLESS OTHERWISE NOTED.
 - 5 - REMOVE ALL FLASH.
 - 6 - PART SHALL BE FREE FROM POROSITY, CRACKING, DEFORMATION AND/OR KNIT MARKS.
 - 7 - FINISH:- EXTERNAL SURFACES MUST HAVE DULL MATTE FINISH.
 - 8 - FINISH $\sqrt{125}$ ALL SURFACES UNLESS OTHERWISE NOTED.

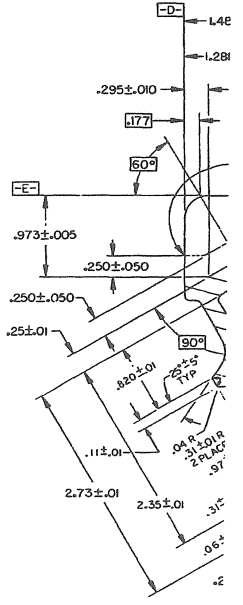
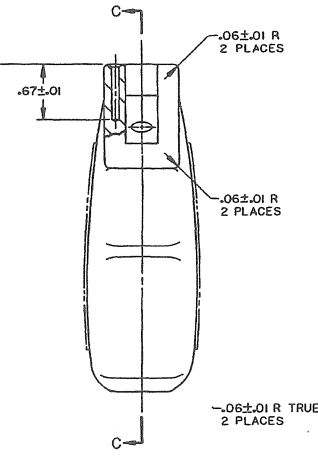
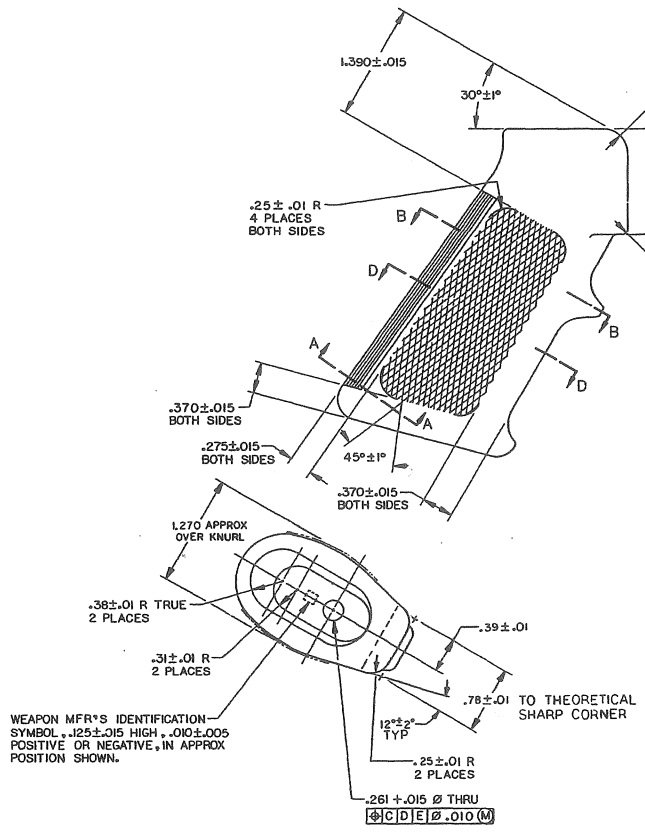
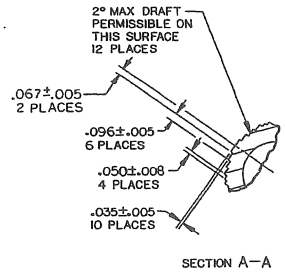
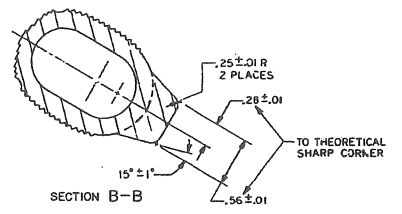
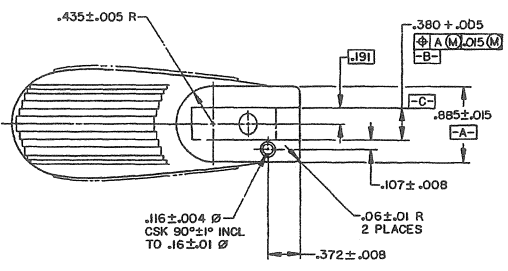

J9349127

F-1/2

REV J

