

**REVISIONS**

1	10/15/04	11:04 AM
---	----------	----------

- NOTES:-
- 1- SPEC. MIL-W-13855 AND ANSI Y14.5-73 APPLY.
  - 2- MATERIAL: PLASTIC COMPOUND PER ASTM D4066, PA 66, COLOR SHALL BE LUSTERLESS (FLAT) APPROX. BLACK NO. 37098, TABLE IX, BUT NOT LIGHTER THAN GRAY, NO. 36076, TABLE VIII OF FED-STD-595.
  - 3- BREAK EDGES .010 ± .005 UNLESS OTHERWISE NOTED.
  - 4- FILLET RADI .009 ± .006 UNLESS OTHERWISE NOTED.
  - 5- ALL EXPOSED SURFACES ENCLOSED IN AREA [S] SHALL HAVE A NONREFLECTIVE MATTE SURFACE, OTHER SURFACES OPTIONAL.
  - 6- TRANSITION OF ANGLES [K], [T] AND [W] SHALL BE SMOOTHLY BLENDED.
  - 7- REMOVE ALL FLASH.
  - 8- PART SHALL BE FREE FROM POROSITY, CRACKING, DEFORMATION, AND FLOW AND/OR KNIT MARKS.
  - 9 FINISH: 125/ ALL SURFACES UNLESS OTHERWISE NOTED.

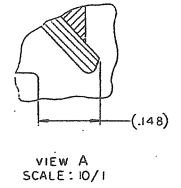
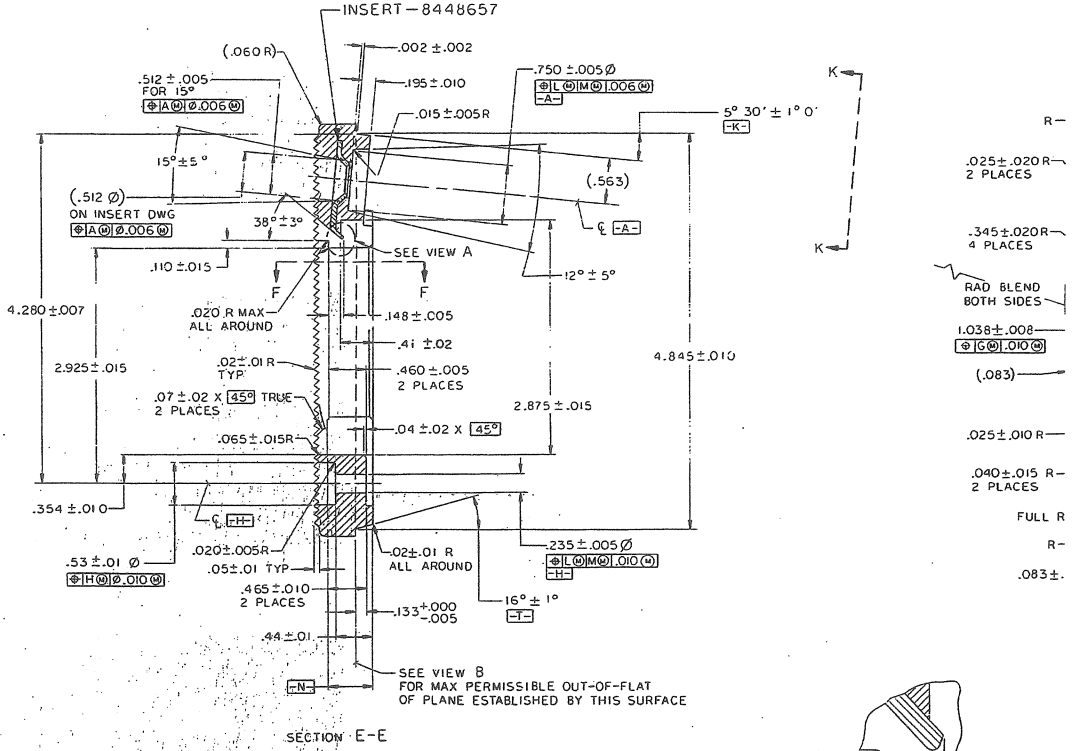
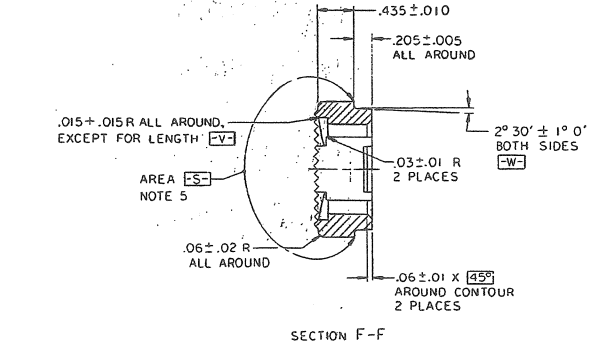
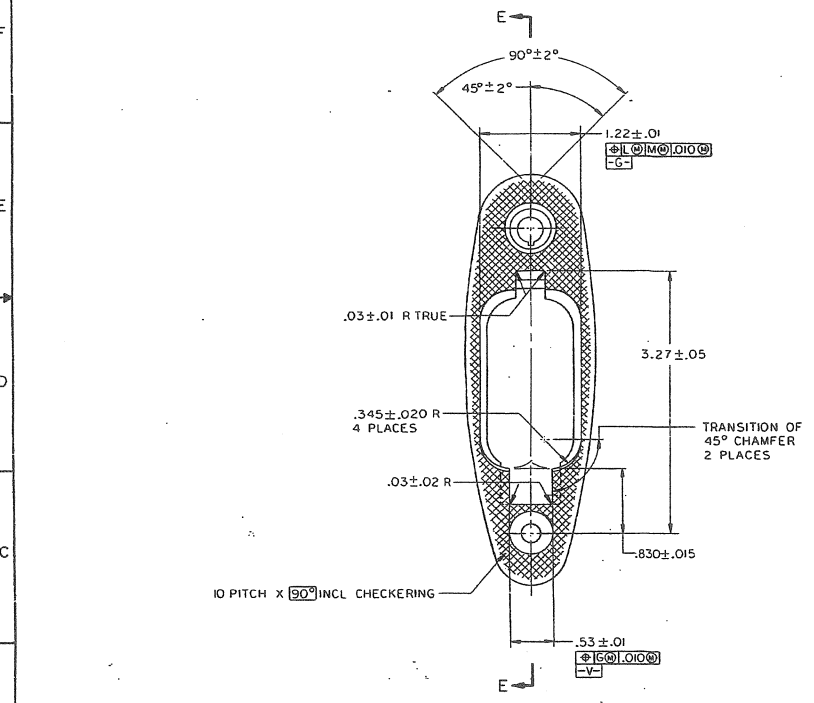

9349130 REV F 1/2

REV	DESCRIPTION	DATE	APPROVAL
-	PRODUCTION RELEASE	82064	<i>A. Haly</i>
-	SRW32013		
A	NOR W50010/84-05-20	84-07-20	<i>W. H. H.</i>
B	NOR W450030/84-11-15	85-04-02	<i>W. H. H.</i>
C	NOR W65006/86-03-12	87-02-29	<i>W. H. H.</i>
D	NOR W58004/86-02-04	89-02-15	<i>W. H. H.</i>
E	REV 75028 BB	89-05-23	<i>W. H. H.</i>
F	NOR GS100 910827	91-10-07	<i>W. H. H.</i>

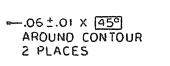
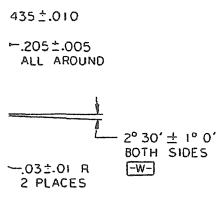

RT-8448657

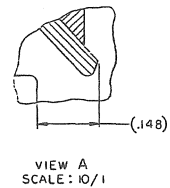
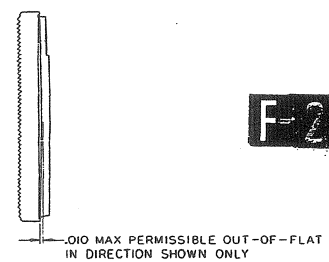
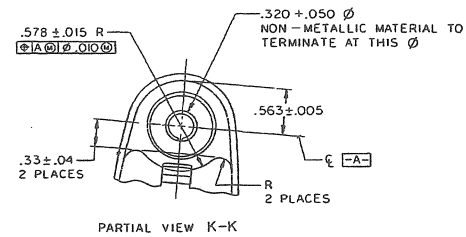
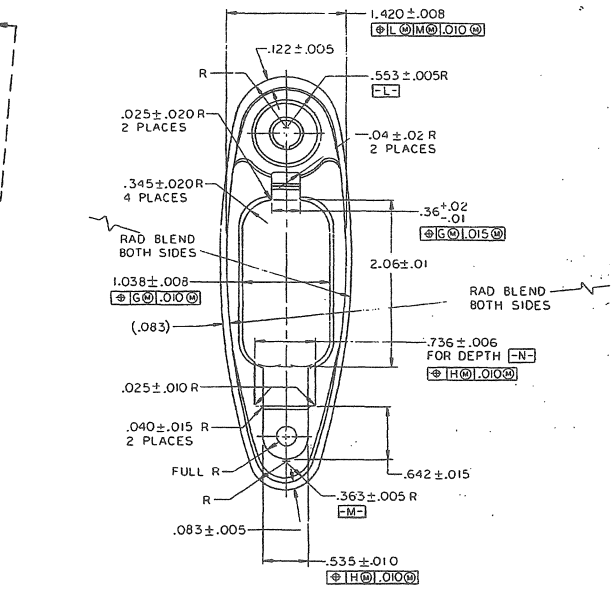
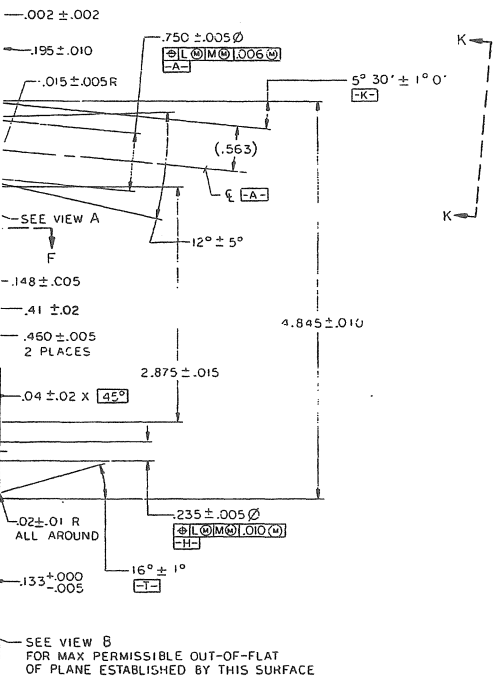

F-2 / 2

FOR ENGINEERING PARTS LIST-SEE PL9349130		PART NO. 9349130	
MECHANICAL PROPERTIES	DO NOT SCALE DRAWING	ORIGINAL SIZE OF DRAWING	U.S. ARMY RESEARCH AND DEVELOPMENT CENTER
TYPE	UNLESS OTHERWISE SPECIFIED DIMENSIONS ARE IN INCHES	82-06-09	GOVERNMENT ACQUISITION CENTER
FINISH	TOLERANCES ON DECIMALS ±	DATE	
TEMP.	FRACTIONS ±	ENGINEER	
RA	ANGLES ±	DRAWN	
SA		CHECKED	
SB		APPROVED	
SC			
SD			
SE			
SF			
SG			
SH			
SI			
SJ			
SK			
SL			
SM			
SN			
SO			
SP			
SQ			
SR			
SS			
ST			
SU			
SV			
SW			
SX			
SY			
SZ			

October 15, 2004 11:04 AM

30 SH REV E