

REVISIONS			
REV	DESCRIPTION	DATE	APPROVAL
-	PRODUCTION RELEASE ERR W353148	84 01 21	
B	NOR W653030/860612 (CP 6753339/870304)	880208	OK DSC VLS
F	NOR 6259510/920514	920622	RL S2

NOTICE: RESTRICTED AS TO USE AND DISCLOSURE
 THIS ENTIRE DOCUMENT AND ALL INFORMATION HEREIN IS PROPRIETARY TO CALTEC INC AND SHALL NOT BE REPRODUCED, REPLICATED OR COPIED IN WHOLE OR IN PART, DISCLOSED OR MADE AVAILABLE TO ANY OTHER PERSON, FIRM, OR CORPORATION OR OTHERWISE USED EXCEPT TO THE EXTENT PERMITTED FOR AND THEN ONLY IN CONNECTION WITH THE PERFORMANCE OF THE SERVICES OF THE CONTRACTOR RELATED TO A PROGRAMMING TASK SPECIFIED BY THE UNITED STATES GOVERNMENT OR IN CONNECTION WITH THE MANUFACTURE IN THE UNITED STATES BY THE UNITED STATES GOVERNMENT OR UNDER A CONTRACT WITH THE UNITED STATES GOVERNMENT. THIS DOCUMENT WILL BE REVISED UPON COMPLETION OF THE PURPOSE FOR WHICH IT WAS ISSUED.

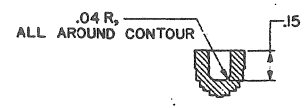

SECTION B-B
SCALE 4/1

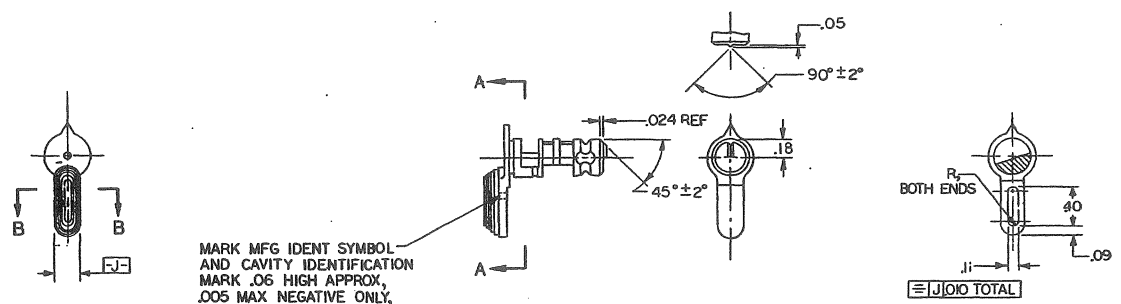

SECTION A-A

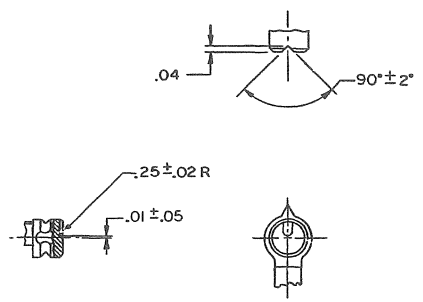

ALTERNATIVE DESIGN

MECHANICAL PROPERTIES		DO NOT SCALE DRAWING		ORIGINAL DATE OF DRAWING		U.S. ARMY RESEARCH AND DEVELOPMENT CENTER	
YIP		UNLESS OTHERWISE SPECIFIED		84-01-25		DURHAM, NORTH CAROLINA	
YS		DIMENSIONS ARE IN INCHES		DRAFTSMAN / CHECKER		SELECTOR, FIRE CONTROL	
ELF		TOLERANCES ON DECIMALS		ENGR / ENGR		SCALE 2/1	
EA		.0002, .0005, .001, .01		ENGR / ENGR		FSCM NO. 9381367	
EA		FRACTIONS ±		ENGR / ENGR		SCALE 2/1	
EA		ANGLES ±		ENGR / ENGR		SHEET 2 OF 2	
EA		APPLICATION		ENGR / ENGR			

PART NO: 9381367

SELECTOR,
FIRE CONTROL

F 19200 9381367

DISTRIBUTION STATEMENT
 FURTHER DISTRIBUTION ONLY AS DIRECTED BY
 AFMHC-OP OR ICHSIS DOD AUTHORITY: 91825

October 13, 2004 3:23 PM