

Customer

Est/Inv Date

Est/Inv Num

### Manson Precision Reamers

8200 Embury Rd  
Grand Blanc, MI 48439

(810) 953-0732 Fax (810) 953-0735

david@mansonreamers.com

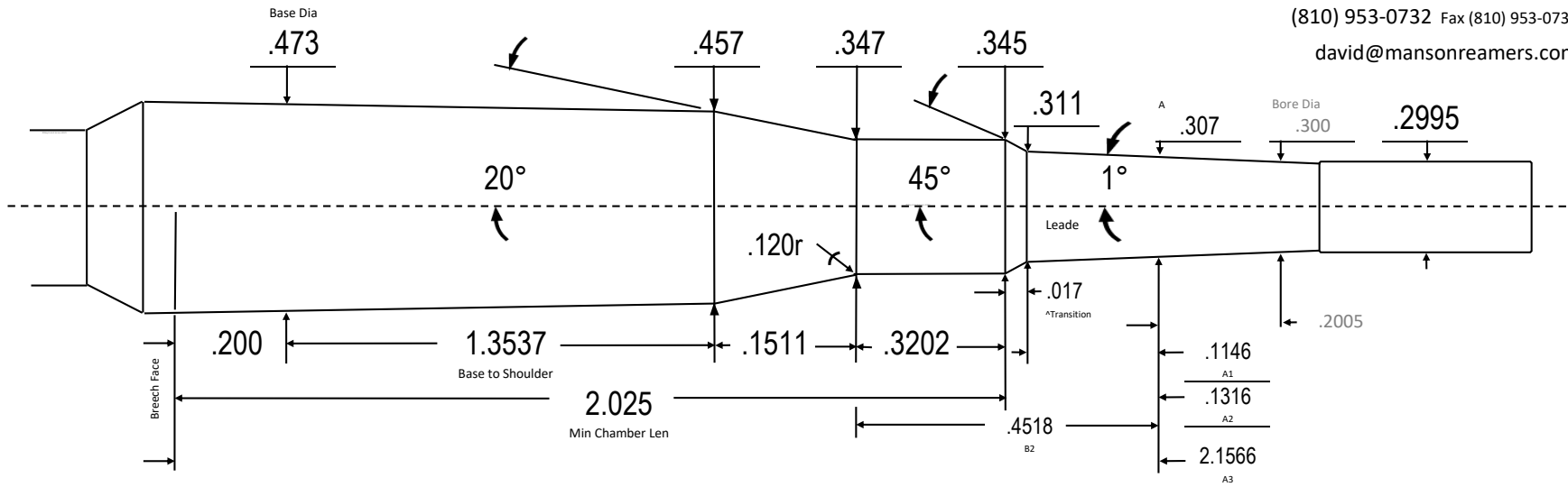

**7.62x51 NATO**

7.62x51 NATO

Standard

Design Date

Revision

Revision

Headspace Gage:	
7.62x51 NATO	
MIN Headspace	1.632
Datum	.400
L1	1.5537
L2	1.7048
Body TPI	.011819
Dia Tolerance	+0.001/-0.000
Length Tolerance	+0.005/-0.000
Angle Tolerance	+/- 10'
~Chamber Vol in <sup>3</sup>	.2845
Transition Fwd	1.2116
Min Blank Len	3.2366
Drawn:	R Gross
Template	v6.8